

## SINGLE CHAIR ASSEMBLY INSTRUCTIONS

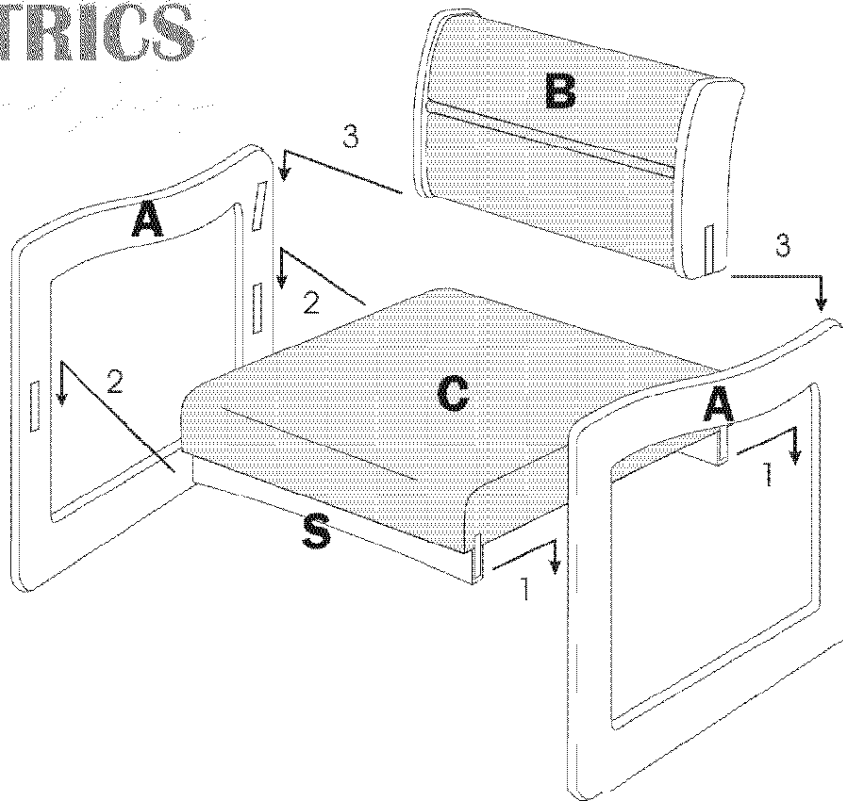

1. Slide brackets on one side of the seat cushion (C) down onto brackets of wood side frame (A). If brackets on the seat (C) don't line up with the brackets of the side frame (A), brackets on the seat skirts (S) can be pulled further apart by hand to line up with the brackets on the frame (A). **Do not** tighten seat (C) onto frame (A) at this time.
2. Repeat step 1 with other side frame (A).
3. Slide back (B) into brackets of both wood sides (A) simultaneously.
4. Push down on chair seat (C) to lock the brackets into place. Inspect front and back of seat to make sure the horizontal wood skirt (S) under seat (C) is not more than 1/8" away from wood sides (A). If so, pull the back (B) and seat (C) off and reset into brackets making sure to keep the wood skirt (S) tight against the side frames (A). Tap down on sides of the back (B) to lock it into place.
5. (Optional) Lock back (B) into place with furnished screws and cover with "Snap Caps."

If you are missing parts, or having complications assembling the chairs or sofas, please call : Toll Free 866-637-4177

# T O T BARIATRICS L

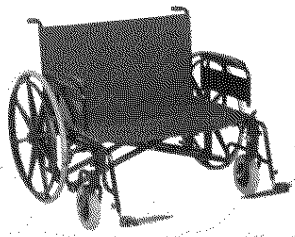

## SINGLE CHAIR ASSEMBLY INSTRUCTIONS OPTIONAL LOCKING SCREW

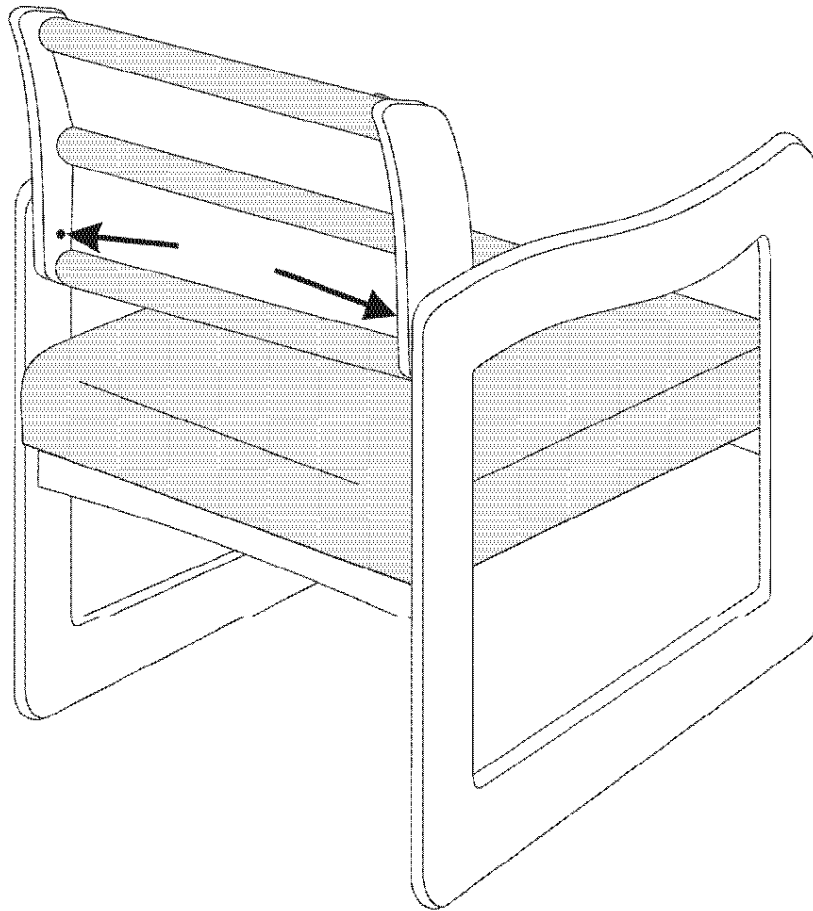

To prevent tampering, an optional locking screw has been provided. Once chair is completely assembled, make sure that the back is slid completely into brackets of side frames. Place screws that are provided into holes in the back side of the back rest being sure that the screw lines up with the small hole on the side frame. Screw in until the screw is snug. Cover with "snap-cap" provided. Repeat with other side.